

PARTS LIST, PH-2 (010065)

<u>KEY</u>	<u>QTY.</u>	<u>PART#</u>	<u>DESCRIPTION</u>
1	1	423277	Breaking nose base
2	1	010019	Roll pin, 1/4 dia. x 1 1/8 long
7	1	010005	Rack
8	1	010043	Gripper pin
9	1	001621	Cotter pin, 3/32 dia. x 1/2 long
10	1	003868	Flexloc nut, 3/8-24 thin
11	1	010011	Gripper
12	1	010021	Handle pivot pin
13	1	010004	Gripper spring
14	1	010016	Gear
15	2	010008	Pawl spring
16	1	010007	Long Pawl
17	1	010014	Ratchet spring
18	1	010006	Short pawl
19	1	010013	Pawl
20	1	010053	Handle
21	1	010054	Handle knob
22	1	010057	Roll pin, 1/4dia. x 1 3/4 long
23	1	010055	Long rack (optional) Slide
24	1	010066	housing
25	1	003133	Warning label
26	1	002485	Nameplate
27	2	002163	Drive screw

⚠ WARNING

Inspect all parts daily and replace them if they are worn or broken. Failure to do this can affect a product's operation and could result in serious personal injury

MAINTENANCE

Clean and apply a light weight machine oil to all moving parts on a weekly basis. Clean the gripper daily with a wire brush. Debris accumulated in the teeth of the gripper must be removed with a small wire brush. A need to clean the teeth will become apparent when the gripper skids on the strap during tensioning.

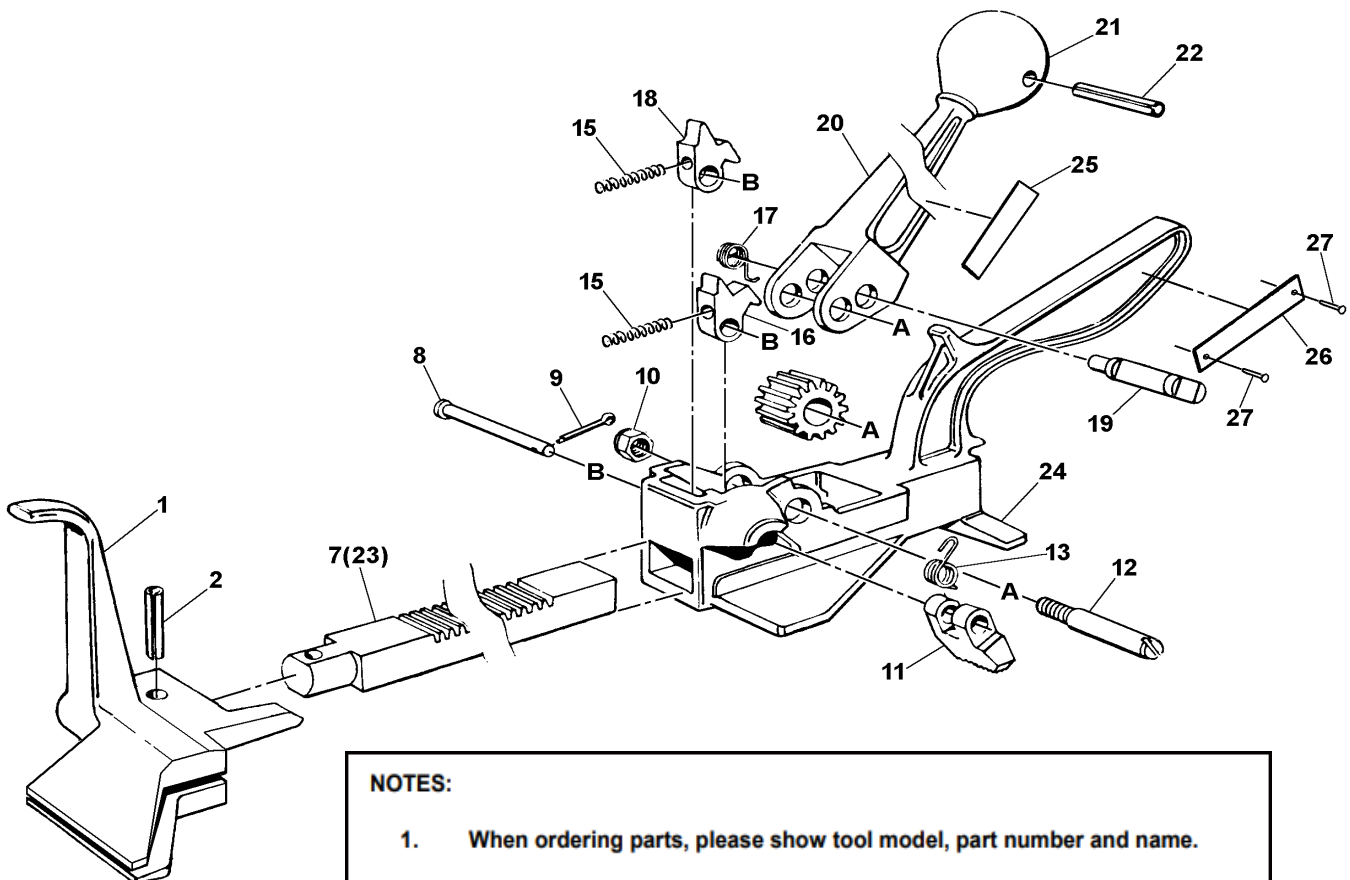

NOTES:

1. When ordering parts, please show tool model, part number and name.
2. All recommended spare parts are underlined and should be stocked.
3. Standard hardware parts may be obtained from local hardware suppliers.